

# What, Me Manage?

Walter Hanig  
3 November 2001

# Agenda

- Why this presentation?
- Work History
- Management Reluctance
- Types of management
- Pros and cons
- Issues peculiar to tech. communications
- Paths into management

# Why This Presentation?

- Open kimono a little
- Demystify management; open eyes
- Encourage self-reflection
- Encourage people to get into management



# Management Reluctance

- Ignorance of what's required besides
  - Setting unreasonable requirements
  - Demanding unachievable schedules
  - Establishing/enforcing stupid policies
- Fear of going over to the dark side

# An Alternate Theory

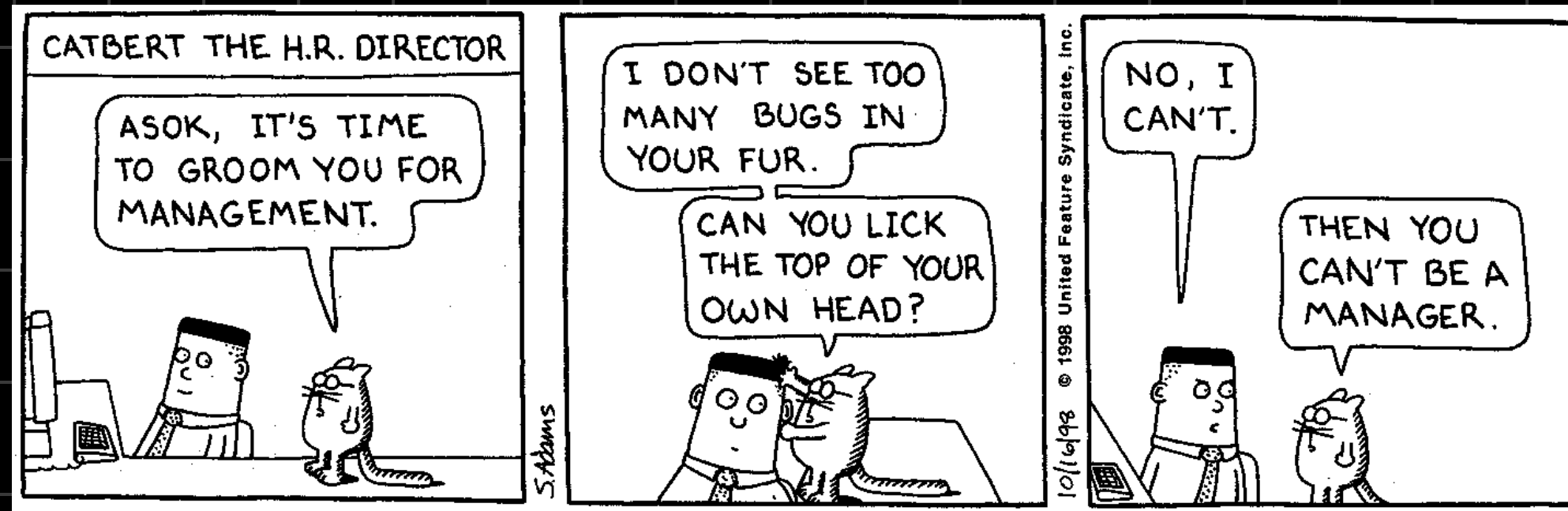

# Types of Management

- Line (functional) management
  - People
- Project management
  - Products: manuals, online help, graphics
- Matrix management
  - Dual reporting structure — line and project

# Typical Line Management

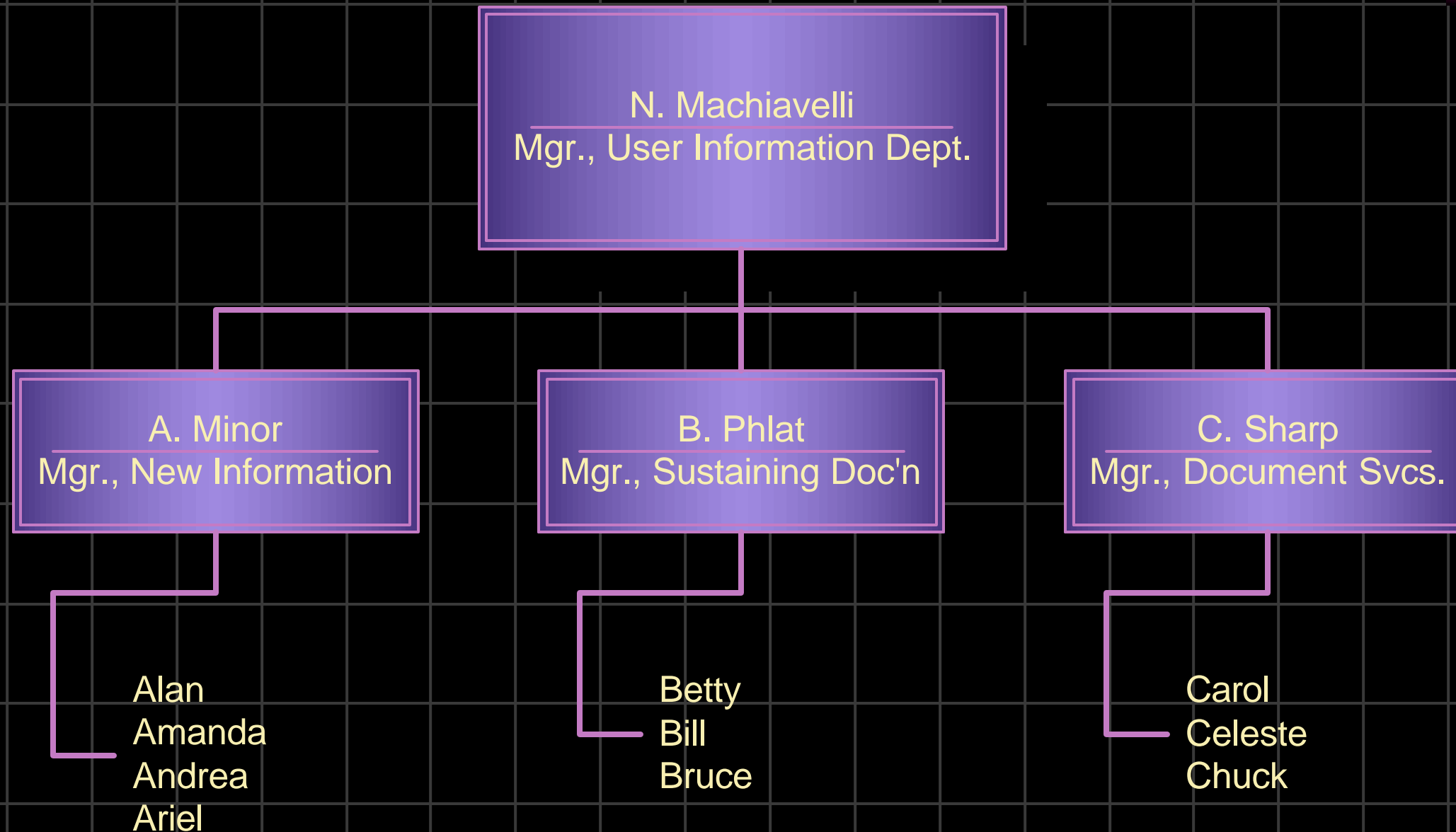

# Typical Project Management

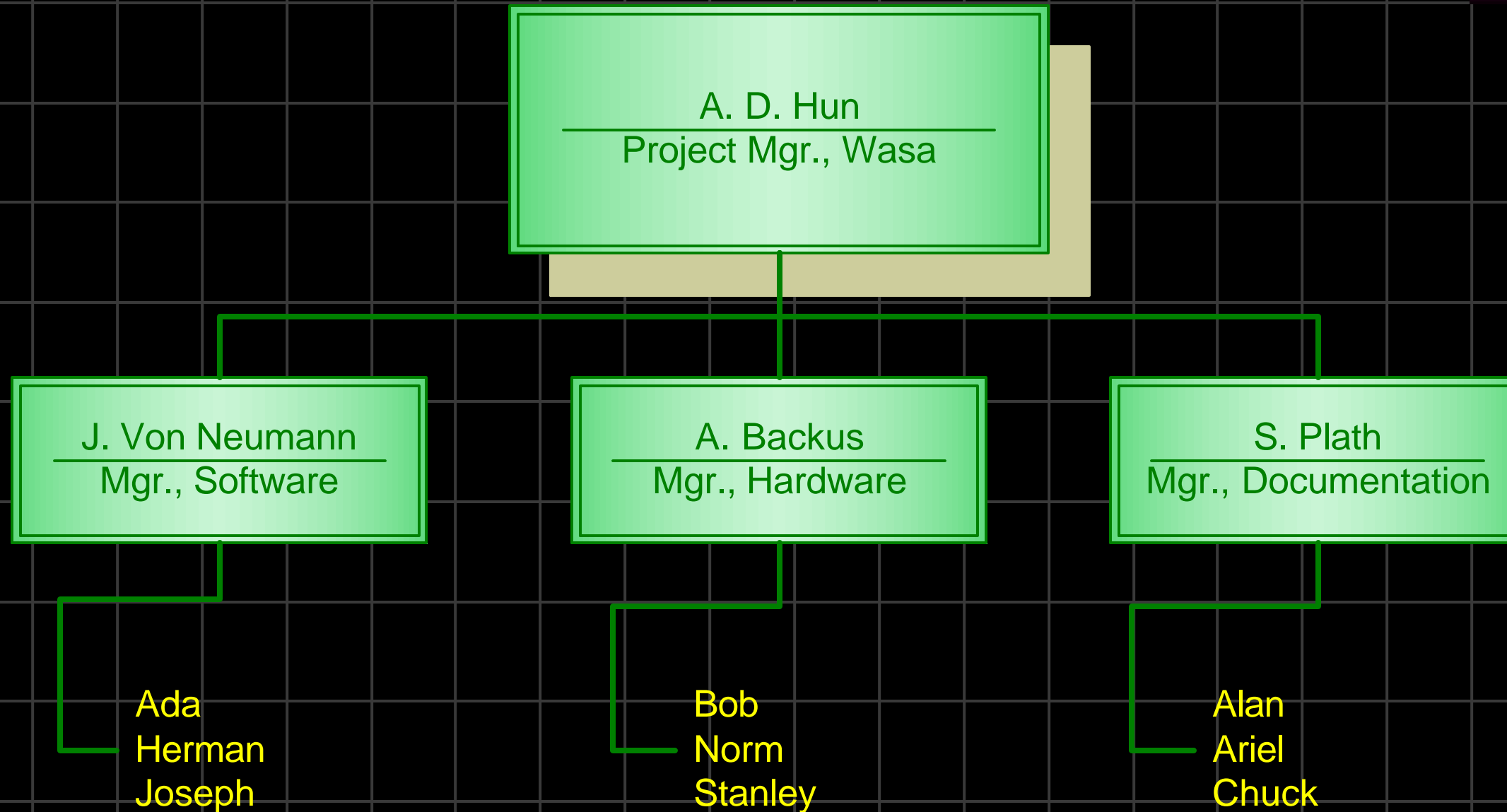

# Typical Matrix Management

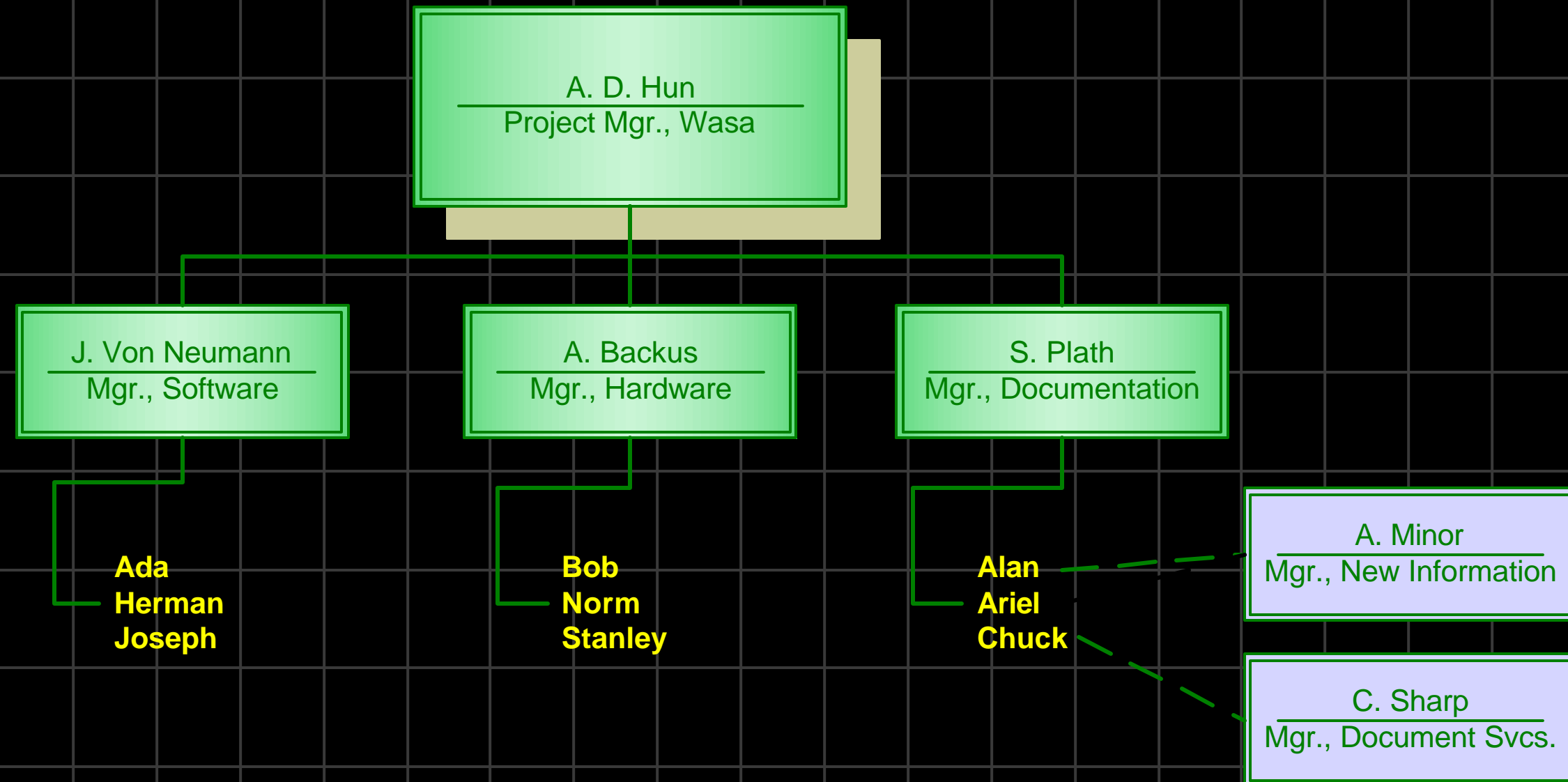

# Line vs. Project Mgt. (1)

## ➤ Primary Responsibility

- Line: people
- Project: projects

## ➤ Duration

- Line: indefinite
- Project: fixed

# Line vs. Project Mgt. (2)

## ➤ Authority

- Line: direct
- Project: direct/indirect, depending

# Line vs. Project Mgt. (3)

## ➤ Where the time goes

- Line

- ✓ Competence planning and training
- ✓ Career development
- ✓ Personalities
- ✓ Assignments
- ✓ Internal marketing

- Project

- ✓ Planning
- ✓ Status
- ✓ Negotiations (scope, schedule, quality, process)

# Line vs. Project Mgt. (4)

## 👉 Interfaces

- Line
  - ✓ Team members
  - ✓ Project leads
  - ✓ Hiring & HR
  - ✓ Line mgt., peers
  - ✓ Boss
- Project
  - ✓ Team members (dynamic)
  - ✓ Project leads
  - ✓ Project bosses
  - ✓ Resource suppliers

# Line vs. Project Mgt. (5)

## ➤ Success defined by

- Line

- ✓ Ease of hiring
- ✓ Career growth
- ✓ Retention
- ✓ Laughter

- Project

- ✓ On-time deliveries
- ✓ Satisfied customers
- ✓ Public visibility
- ✓ T-shirts

# Line vs. Project Mgt. (6)

## ➤ Toughest issues

- Line

- ✓ Style differences
- ✓ Personal problems
- ✓ Conflicts between people or people and their goals

- Project

- ✓ Dependency on others
- ✓ No control over who's on the team
- ✓ Personality issues
- ✓ Tradeoffs among objectives

# Line vs. Project Mgt. (7)

## ➤ Satisfiers

- Line

- ✓ Personal & professional growth
- ✓ Career options
- ✓ Team-sense

- Project

- ✓ Team facilitation leading to team accomplishment
- ✓ Knowledge of overcome hurdles
- ✓ Project glory

# Line vs. Project Mgt. (8)

## ➤ Why do it?

- Line

- ✓ Mentoring
- ✓ Advancement opportunity beyond writing, editing, graphics, DTP
- ✓ New challenges (people)

- Project

- ✓ Greater accomplishment
- ✓ New challenges (budget, planning)
- ✓ Route to project management beyond Technical Communication

# Pros and Cons (1)

- Management is *right* for you if
  - Satisfiers satisfy you
  - You're OK with dependency
  - You're invigorated by smarter, more innovative people
  - You're OK with being one of "them"
  - You can be cool when panic is appropriate
  - You've been wrong before and will be again
  - You can handle tears

# Pros and Cons (2)

- Management is *wrong* for you if
  - You need ownership
  - You're accomplishment-driven or defined
  - You're not confident in your judgments
  - Conflicts make you ill
  - You need to be close to people
  - You dislike parenting
  - You can't keep a secret

# Technical Comm. Issues

## ➤ Reporting Structures

- R & D
- Product Management
- Marketing
- Training
- QA

## ➤ Personality types

## ➤ Product timing

## ➤ Respect

# Paths into Management

- Small-scale project management
- Newbie training
- Technical expertise
- Task forces

# Summary

- Line vs. project management
- Know yourself
- You can be one of “them” without losing “you”
- It’s OK to be the boss
- Want my job?